



Shoebox NX Heat Pump

Features and Benefits

- **5.8 kW output**
- **Quiet operation**
- **Low running costs**
- **High SCOP**
- **A+++ ERP**
- **Simple installation**
- **UK manufactured**
- **Integral vibration dampening**
- **Low power consumption**
- **Single phase**
- **Small footprint**
- **Perfect for Networked Heat Pumps**



Product Description

The Kensa Shoebox NX heat pumps are designed to provide space heating and domestic hot water for newbuild and retrofit applications.

The Shoebox NX heat pump is designed specifically to operate with low noise levels.

The Shoebox NX heat pump comes complete with a ground-side water pump internal to the unit, reducing the complexity of the installation. The Shoebox NX has low sound emissions compared to other heat pumps on the market, allowing for flexibility in installation location.

Kensa heat pumps use low-grade renewable energy. Each heat pump concentrates this energy into a high-temperature output to provide heating and hot water to the dwelling.

All Shoebox NX heat pumps come with integrated non-return valves as standard.

As a UK manufacturer, Kensa offers a high-quality product that is supported by industry-leading technical support to ensure the application engineering is performed to the highest standard.



Shoebox NX Heat Pump

Single Phase	
Nominal thermal kW rating	5.8
MCS approved	BBA 0055/45
Product Code	S5 P0K
Performance data—rated heating output at B0/W35 BS EN14511	
Power consumption (kW)	1.35
Coefficient of Performance* (COP)	4.36
Immersion heater output	Kensa heat pumps do not feature back-up electric immersion heaters**
Brine (primary) based on 0°C in, -4°C out	
Design flow rate (l/min)	16.3
Pressure drop at design flow rate (kPa)	20
Max inlet temperature (°C)	25
Min temperature (°C) (Outlet)	-5 (at standard settings)
Heating water (secondary) based on 30°C in, 35°C out	
Design flow rate (l/min)	17.0
Pressure drop at design flow rate (kPa)	10.2
Max flow temperature (°C)***	64
Electrical Values @B0/W35	
Rated Voltage (V)	220-240/ 50 Hz
Power supply current rating (A)	16
Rated current max (A)	11.6
Typical running current @ B0/W35 (A)	6.6
Starting current (A)****	12.2
Power Factor @ 0/35C	0.95



Shoebox NX Heat Pump

Performance data—rated heating output at B0/W55 BS EN14511	
Power consumption (kW)	1.78
Coefficient of performance* (COP)	2.98
Heating water (secondary) based on 47°C in, 55°C out	
Design flow rate (l/min)	9.72
Pressure drop at design flow rate (kPa)	3.33
Electrical Values @B0/W55	
Rated voltage (V)	220-240V/ 50 Hz
Power supply current rating (A)	16
Rated current max (A)	11.6
Typical running current @ B0/W55 (A)	8.8
Starting current (A) ****	12.2
Power Factor '@0/55C	0.89

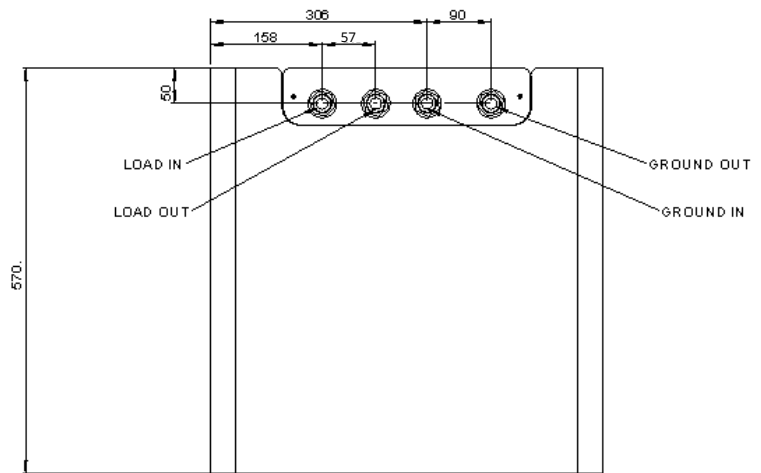
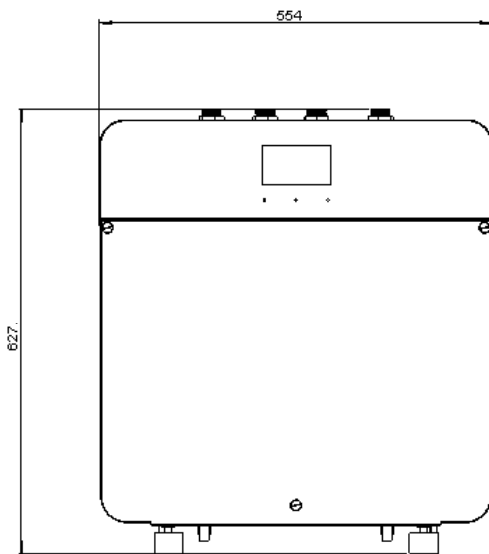

* The COP figure quoted excludes the water pump electrical input and is calculated according to EN14511.

** In-built immersion heaters will increase running costs and CO₂ emissions as they use direct electricity, because of this Kensa heat pumps do not include them.

*** By increasing the flow temperature from the heat pump, the efficiency of the unit will drop and the COP decreases.

**** The starting currents are per phase. For full details on how the starting currents are calculated please contact Kensa.

Note: Design flowrates and pressure drops are based on a ground temperature of 0 and -3°C and a load temperature of 30°C and 35°C or 47°C and 55°C



Shoebox NX Heat Pump

Refrigerant circuit	
Process medium	R407C
Fill volume (kg)	1.1
Compressor type	Scroll
Dimensions (nominal)	
Height (mm)	627
Width (mm)	554
Depth (mm)	570
Dry weight (kg)	93
Operating pressure	
Brine circuit min primary (bar gauge)	Configured at commissioning
Heating water circuit min secondary (bar gauge)	Configured at commissioning
Low pressure reset (bar gauge)	Configured at commissioning
Connection sizes	
Primary IN and OUT	3/4" BSP Parallel with 22mm
Heating flow and return	
Performance (based on Average Climate) @35°C	
ErP rating	A+++
SCOP	4.60
Seasonal space heating energy efficiency	176%
Performance (based on Average Climate) @55°C	
ErP rating	A++
SCOP	3.65
Seasonal space heating energy efficiency	138%
Sound Power Level	
dB	51.2

Warning— when a heat pump is solely used for heat domestic hot water, it may not get the water hot enough to kill the dangerous legionella that can breed in hot water cylinders. Alternative arrangements may therefore be required to ensure the cylinder is pasteurised regularly. The installer/end user should check if this pasteurisation is required by local regulations, bearing in mind that there are often different rules for installations in rented or commercial properties.